



**PRODUCT BULLETIN
MODEL SHORT-SET CAN WITH
FABRICATED STEEL HEAD
VERTICAL TURBINE**

Short Set Can With Fabricated Steel Head Vertical Turbines

The American-Marsh Vertical Turbine pumps are designed for long, dependable life in many applications. Modern processing methods require modern pumping equipment to satisfactorily handle the many and varied fluids used in the various industries. American-Marsh Engineers, backed by over 125 years of manufacturing experience, have met this demand with the vertical turbines offered today. We have incorporated in our design, ideas and suggestions from competent engineers from all sections of the country.

Material Specifications

	CONSTRUCTION		
	BRONZE FITTED	ALL IRON	ALL BRONZE
Bowl Assembly	Cast Iron	Cast Iron	Bronze
Bowl Bearings	Bronze	Bronze	Bronze
Impeller(s)	Bronze	Cast Iron	Bronze
Bowl Shaft	416 SS	416 SS	416 SS
Strainer	Galvanized Steel	Galvanized Steel	Galvanized Steel
Discharge Column	A53 Steel	A53 Steel	A53 Steel
Column Shaft	C1045 Steel	C1045 Steel	C1045 Steel
Column Bearings	Rubber	Rubber	Rubber
Discharge Head	Cast Iron	Cast Iron	Cast Iron

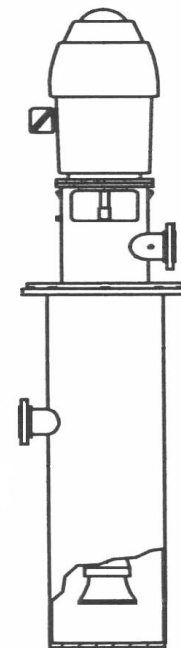

PUMPING CONDITIONS:

Fluid to be Pumped:
Design Capacity (USGPM):
Differential Head (FEET):
Maximum RPM:
Minimum acceptable bowl efficiency, (%):
Viscosity (SSU):
Specific Gravity:
Suction Pressure (PSIG)
Temperature (°F):

INDUSTRIAL
Process, Petrochemical,
Cargo Transfer

COMMERCIAL
HVAC, Booster, Supply Water

MUNICIPAL
Quench Water, Filtration, Transfer,
Filter Backwash, Circulation

**PRODUCT BULLETIN
MODEL VERTICAL TURBINE**

MODEL SHORT SET CAN WITH FABRICATED STEEL HEAD VT SPECIFICATIONS

Bowl Assembly: The pump bowls shall be of close grained, cast iron ASTM A48 Class 30. The water passages on bowl sizes 6" through 16" shall be lined with porcelain enamel or fusion epoxy lined to reduce friction loss, shall be free of blow holes, sand holes and other detrimental defects, and shall be accurately machined and fitted. The impellers shall be of bronze (enclosed or semi-open) and dynamically balanced. Impellers through 16" shall be securely fastened to the shaft with taper split bushings of steel. Larger sizes shall be double-keyed. Impellers shall be adjusted vertically by an external means.

The pump shaft shall be of A582 grade 416 stainless steel, turned, ground and polished. It shall be supported by bronze bearings above and below each impeller. The suction case bearing shall be grease lubricated and protected by a bronze sand collar. The size of the shaft shall be no less than that determined by ANSI/AWWA Specifications E101, Section A4.3 paragraph 4.3.3.

Column Assembly: The butting faces shall be machined square to the axis of the shaft, with maximum permissible axial misalignment on the thread axis with the shaft axis 0.002" in 6". The size of the shaft shall be no less than that determined by ANSI/AWWA-E101 Specifications Section 5.5 for C1045 lineshaft and shall be such that elongation due to hydraulic thrust will not exceed the axial clearance of the impellers in the pump bowls. Maximum runout in 10' shall not exceed 0.005".

The lineshafts shall be provided with ASTM A269 grade 304 stainless steel threaded sleeves at the location of each lineshaft bearing. The use of glues or any other means of securing the sleeve to the shaft, that is not field replaceable without the use of heat or special tools is not acceptable. The lineshaft bearing shall be of 70 minimum shore hardness, neoprene, snap-in type, internally spiral grooved to flush out sand and other abrasives, mounted inside bronze bearing retainers held in position in the column pipe. Bearing spacing shall not exceed 10' for 1800 RPM of 5' for 2200 RPM and above.

The outer column pipe shall be 5" and larger of ASTM A53 grade B steel pipe of ASTM A120 in interchangeable sections not over 10' in length for 1800 RPM and 5' in length for 2200 RPM and above.

THREADED: The ends of each section faced parallel and machined with 8 straight threads per inch permitting the end to butt and insuring alignment when connected by standard mill steel coupling.

FLANGED: The column assembly shall be flanged and machined to accept bearing retainer in such a way as not to allow any movement of retainer after flanges are bolted securely together and to implement proper sealing of the column. The weight of the column pipe shall be no less than that stated in ANSI/AWWA Specification E101, Section 5.1 "Standard Specifications for Discharge Column Pipe." The column size shall be such that friction loss will not exceed 5' or 100', based on the rated capacity of the pump. If possible, the column size shall be such also be such as to provide a velocity of not less than 5 feet per second at the rated capacity.

Top and bottom sections of column pipe on product lubricated pumps shall not exceed 5' in length.

Discharge Head: The discharge head shall be of Schedule 40 fabricated steel, free from defects, accurately machined and with a surface discharge. Discharge flange shall be machined and drilled to ANSI

standards for _____ pounds rating faced shall be _____ inches nominal inside diameter. The top of the discharge head shall have a rabbet fit to accurately locate the vertical hollow shaft driver, and have a diameter equal to the driver base diameter (BD) and less than _____ inches.

Stuffing Box: The seal arrangement provided shall be one of the following (packing or mechanical seal):

The standard cast iron stuffing box shall be rated for 125 PSI discharge pressure and shall be fitted with graphite acrylic packing. It shall have a lantern ring or grease chamber placed as required below the top packing ring. Throttle bearing shall be bronze with stainless steel bolting and with brass or stainless steel adjusting nuts. Sealing between the stuffing box and the discharge head shall be accomplished by means of an o-ring.

If the discharge pressure exceeds 125 PSI, a high pressure bypass style packing box shall be supplied with a minimum of six rings of packing and two lantern rings and a bypass to sump.

A unit which requires a mechanical seal shall have a housing bolted to the head with an o-ring seal. The housing shall have a lower bronze throttle bushing. The housing seal chamber shall accommodate a single sleeved (balanced/unbalanced) mechanical seal suitable for the maximum pressure developed by the pump of _____ PSI and temperature _____ °F maximum. Seal materials shall be compatible with the liquid pumped. A balanced seal shall be mounted on a shaft sleeve. The shaft supplied shall be one-piece bowl, line and head-shaft where practical of 416 stainless steel material.

Motor: The electric motor shall be vertical hollow shaft _____ RPM., three phase (50 or 60 Hz) _____ volts with a non-reverse ratchet, P-base, squirrel cage induction design. Enclosure shall meet NEMA weather protected type type 1 design with stainless steel screens to prevent entrance of rodents. Motor shall have Class B or Class F insulation with temperature rise as specified by NEMA standards for class insulation used and shall have a 1.15 service factor.

Thrust bearing shall be chosen to handle the continuous down thrust as specified by the pump manufacturer with an AFBMA B-10 one-year minimum or five year average life under design conditions. Provisions shall be made for momentary upthrust equal to 30 percent of rated down thrust. The motor rating shall be such that at design it will not be loaded beyond nameplate rating and at no place on the pump curve shall the loading exceed the service factor.

Suction Barrel: The unit shall be supplied with a fabricated steel suction barrel. The barrel shall be capable of containing the maximum suction pressure supplied to the suction flange. The bottom end of the suction barrel shall be supplied with a welded plate cap dor water service. A weld cap shall be supplied for all hydrocarbon service applications.

The barrel shall be equipped with a square base plate which shall be machined and tapped to match the discharge head base flange supplied. The base shall be drilled to allow the barrel to be secured in place with anchor bolts. Barrel shall be supplied with proper gasket or o-ring and bolting for application to seal between the barrel flange and the head base flange.

WATER LUBRICATED TURBINE PUMP SECTIONALS

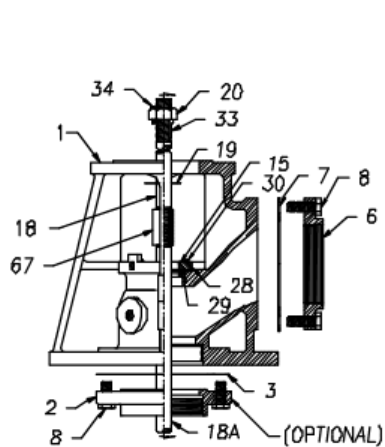

TYPICAL STANDARD HEAD

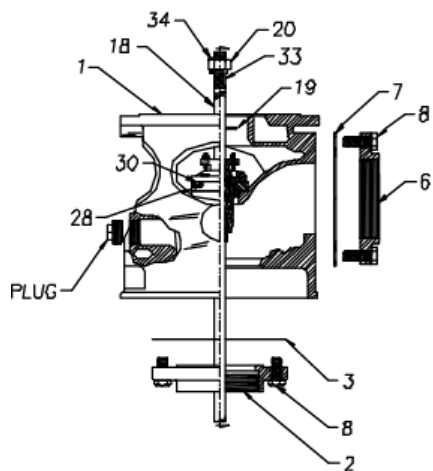

TYPICAL HEAVY DUTY HEAD

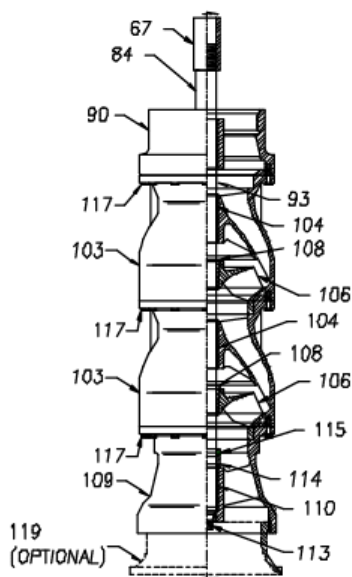

BOWL ASSEMBLY

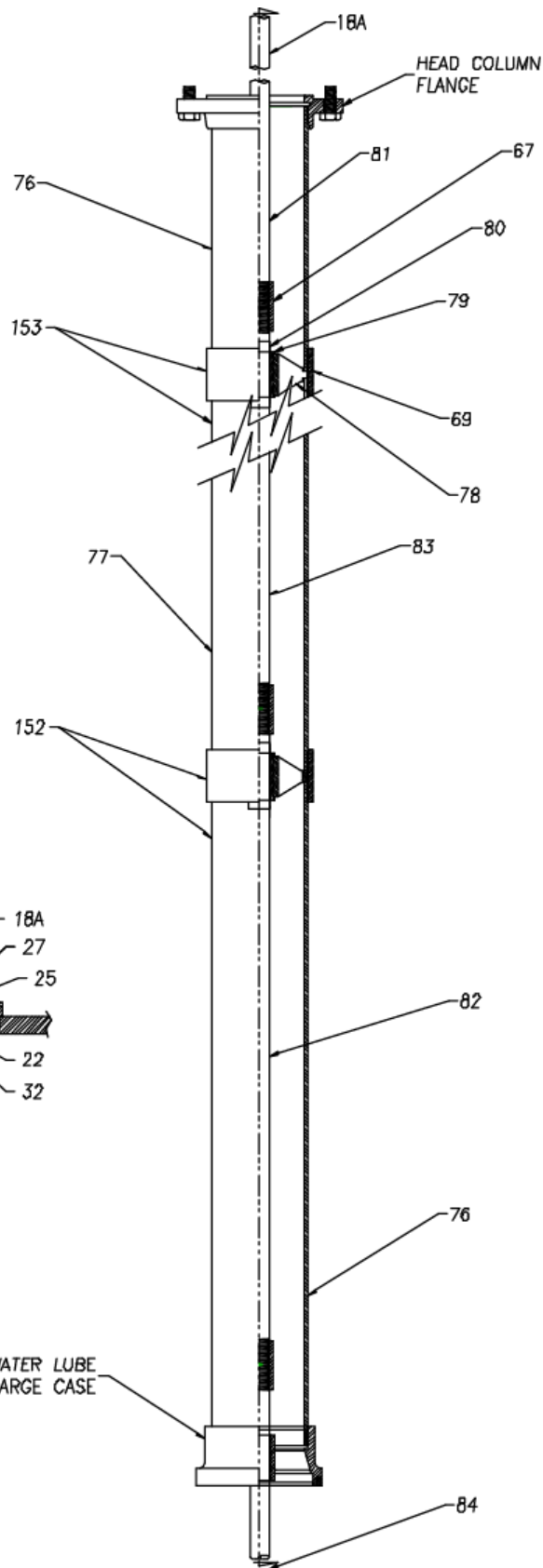
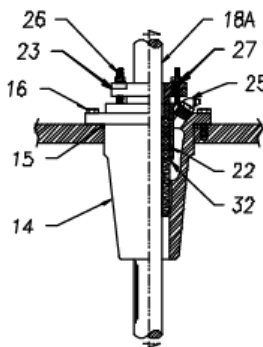

OIL LUBRICATED TURBINE PUMP SECTIONALS

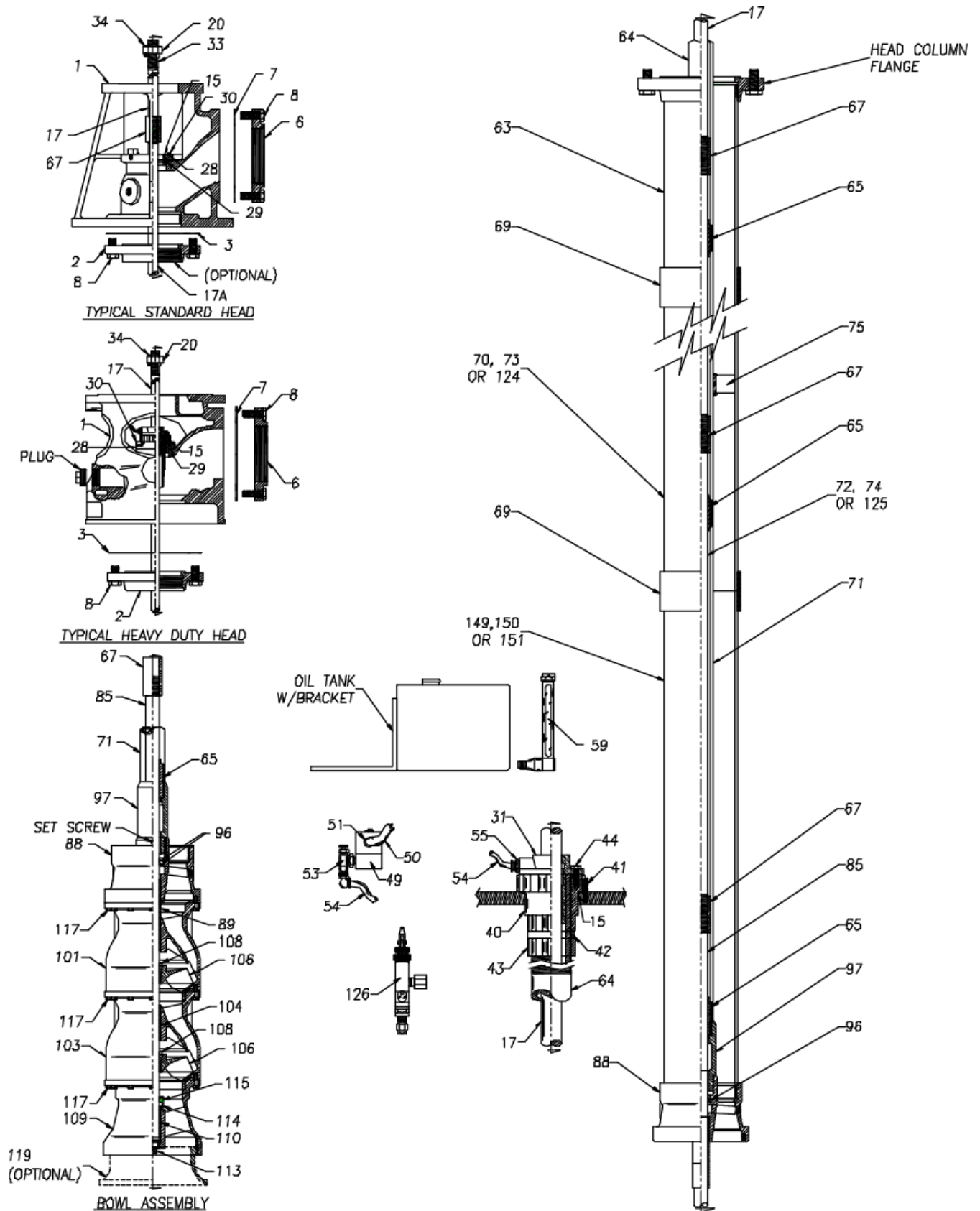

SHORT SET CAN WITH FABRICATED STEEL HEAD SECTIONAL DRAWING

Item Number	Item Description
1	Discharge Head
2	Head Column Flange
3	Head Column Flange Gasket
4	Studs
5	Nuts
6	Head Discharge Flange
7	Head Discharge Flange Gasket
8	Discharge Flange Assembly Cap Screws
9	Discharge Flange Assembly Nuts
10	Head Discharge Flange Assembly Studs
11	Head Discharge Flange Assembly Nuts
14	Head Packing Housing with Bearing
15	O-Ring
16	Head Packing Housing Cap Screws
17	Oil Lubricated Headshaft
18	Water Lubricated Headshaft
18A	Top Shaft
19	Headshaft Flinger
20	Headshaft Adjusting Nut
22	Packing (Set)
23	Packing Follower
25	Head Packing Housing Grease Fittings
26	Packing Follower Studs
27	Packing Follower Retainer Nuts
28	Adapter Flange
29	Adapter Flange O-Ring
30	Adapter Flange Assembly Cap Screws
31	Oil Lubricated Headshaft Bearing
32	Water Lubricated Headshaft Bearing
33	Water Lubricated Headshaft Bearing
34	Adjusting Nut Machine Screw
40	I/C Tension Nut
41	Tension Nut Set Screw
42	I/C Seal Ring
43	I/C Seal Ring Nut
44	Headshaft Bearing Assembly Cap Screws
45	Headshaft Bearing Dust Seal
49	Solenoids Valve
53	Vented Sight Drip Valve
54	Tubing for Oil Lubrication
55	Oil Line Connector for Headshaft Bearing
59	Oil Level Sight Glass
63	2' Long O/C Adapter Nipple TBE Top Section
64	Inner Column Adapter 2' 4" Long Stretch Nipple
65	Oil Lubricated Lineshaft Bearing
66	Oil Lubricated Lineshaft Adapter Bearing
67	Shaft Coupling
68	Shaft Adapter Coupling
69	O/C Coupling

Item Number	Item Description
70	Oil Lubricated O/C Section (10' 0" long) TBE
71	I/C Section (5' 0" long)
72	Oil Lubricated L/S Section (10' 0" long)
73	Oil Lubricated O/C Section (5' 0" long) TBE
74	Oil Lubricated L/S Section (5' 0" long) TBE
75	I/C Stabilizing Spider
76	Water Lubricated O/C Section
77	Water Lubricated O/C Section
78	Water Lubricated L/S Bearing Spider
79	Water Lubricated L/S Bearing
80	Water Lubricated L/S Sleeve
81	Water Lubricated L/S Extension (3' 9-7/8" long)
82	Water Lubricated L/S Section (5' 0" long)
83	Water Lubricated L/S Section (10' 0" long)
84	Water Lubricated Bowl Shaft
85	Oil Lubricated Bowl Shaft
88	Oil Lubricated Discharge Case
89	Oil Lubricated Discharge Case Bearing
90	Water Lubricated Case Bearing
91	Water Lubricated Case Bearing
93	Water Lubricated Case Bearing
94	Sand Cap Set Screws
96	Shaft Seal
97	I/C Adapter Coupling
101	Top Bowl Assembly
102	Top Bowl Bearing
103	Bowl Assembly (Enclosed Type)
104	Bowl Bearing
105	Bowl Assembly (Semi-Open Type)
106	Impeller (Enclosed Type)
107	Impeller (Semi-Open Type)
108	Taper Lock
109	Suction Case Assembly (Enclosed Type)
110	Suction Case Bearing
111	Suction Case Assembly
113	Suction Case End Plug
114	Suction Case Sand Cap
115	Optional Set Screws for Brass Sand Cap
116	Bowl Suction Flange
117	Bowl Assembly Cap Screws
119	Suction Bell (Optional)
124	Oil Lubricated O/C Section (20' 0" long)
125	Oil Lubricated L/S Section (20' 0" long)
126	Vented Toggle Valve
149	Oil Lubricated O/C Assembly T&C (10' 0" long)
150	Oil Lubricated O/C Assembly T&C (5' 0" long)
151	Oil Lubricated O/C Assembly T&C (20' 0" long)
152	Water Lubricated O/C Assembly T&C (10' 0" long)
153	Water Lubricated O/C Assembly T&C (5' 0" long)

Recommended spare parts are in **BOLD**.

SHORT SET CAN WITH FABRICATED STEEL HEAD VERTICAL TURBINE

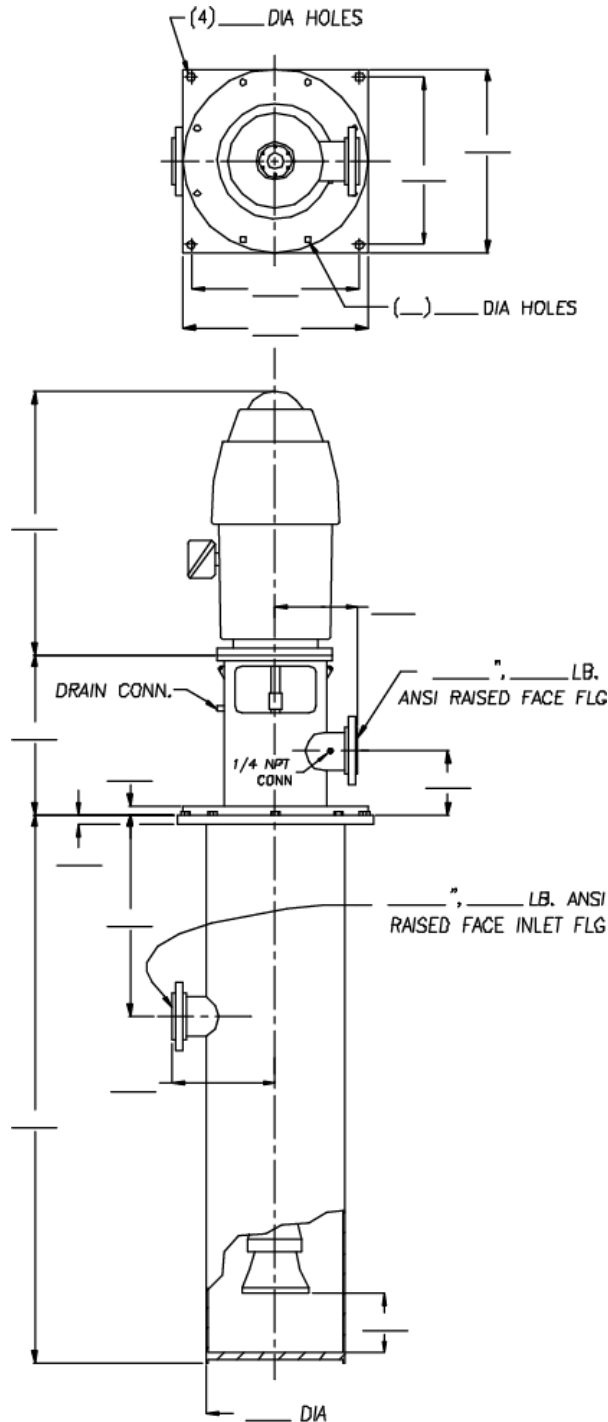

MATERIALS OF CONSTRUCTION

BOWL	IMPELLER
BOWL SHAFT	SHAFT COUPLING
BOWL BEARINGS	SHAFT BEARINGS
STRAINER	BOWL W/R
IMPELLER W/R	COLUMN PIPE
LINESHAFT	PACKING
BASE PLATE	DISCHARGE HEAD

PUMP

TYPE	DISCHARGE HEAD
SUCTION	DISCHARGE
LINESHAFT	COLUMN
LUBRICATION	MODEL
STAGE	GPM
TDH	TRIM
RPM	BHP

MOTOR

MAKE	TYPE
ENCLOSURE	NRR
SRC	HP
RPM	PHASE
HERTZ	VOLTAGE
FRAME NO.	TYPE COUPLING

OTHER SPECIFICATIONS

DRAWING NO.	SERIAL NO.
FLUID	SPECIFIC GRAVITY
VISCOSITY	TEMPERATURE
PH	NO. UNITS REQUIRED

CUSTOMER		
ADDRESS		
CITY	ST	ZIP
TEL. ()	FAX. ()	
REP.		
SUPPLIER		
SALESMAN		

- Your Local Authorized Distributor -



Sales & Marketing: 185 Progress Road • Collierville, Tennessee • 38017

Manufacturing: 185 Progress Road • Collierville, Tennessee • 38017

Phone: (800) 888-7167

Fax: (901) 860-2323