

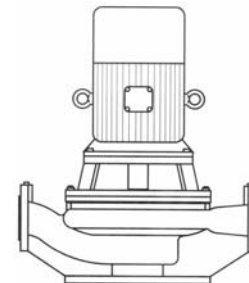

PRODUCT BULLETIN MODEL REI END SUCTION

American-Marsh Model REI End Suction pumps are used in a variety of industries. These rugged and efficient centrifugal pumps are designed for long life and low operational costs. Each model is of the back pull out design so when the need arises for repair or inspection, system piping does not need to be disturbed. REI models offer centerline suction and discharge and can be mounted in several different orientations. The REI product line surpasses other competitor product lines in that it spans sizes from 2” all the way up to 14” discharges.



Material Specifications

PART	CONSTRUCTION			
	BRONZE FITTED	IRON FITTED	NI-RESIST FITTED	316SS FITTED
Casing	Cast Iron	Cast Iron	Cast Iron	Cast Iron
Impeller	Bronze	Cast Iron	Ni-Resist	316 Stainless Steel
Shaft	420 Stainless Steel	420 Stainless Steel	420 Stainless Steel	420 Stainless Steel
Shaft Sleeve	Bronze	Bronze	316 Stainless Steel	316 Stainless Steel
Case Wear Ring	Bronze	Cast Iron	Ni-Resist	316 Stainless Steel
Bolts, Studs & Nuts	Steel	Steel	Steel	Steel
Mechanical Seal	Carbon/Si-C/Buna	Carbon/Si-C/Buna	Carbon/Si-C/Buna	Carbon/Si-C/Buna

MODEL REI SPECIFICATIONS

Casing: The casing is constructed of high tensile cast iron or other specified material. It is of the volute type, carefully and accurately proportioned to permit smooth flow and to convert high velocity energy of the fluid as it leaves the impeller into pressure. Suction and discharge nozzles are casted integral with the volute and are of 250 psi dimensions. All REI models feature a 250 psi case working pressure. The casing has a cast integral foot standard with the suction and discharge ports are on the same centerline. Necessary vent and drain openings are provided.

Impeller: The impeller is of the end suction type, casted in one piece of bronze or other specified material. All impellers are hydraulically and dynamically balanced prior to assembly and all impellers have pump out vanes standard on the back side of the impeller to reduce material from building up near the stuffing box.

Case Wear Ring: Standard enclosed impellers are designed with integral case wear rings accurately turned to provide close running fits in casing. The diameters of these rings are such as to reduce end thrust to a minimum. On larger models a rear case wear ring is provided for additional wear resistance.

Shaft: The shaft is of high strength 420 stainless steel, ground to accurate dimensions and polished to a smooth surface. It is designed

for extra stiffness to avoid all critical speeds in operation. The shaft is protected by a shaft sleeve of ample thickness to ensure long life. The shaft sleeve can be supplied in various materials.

Casing Adapter: The casing adapter is constructed of cast iron or other specified material. The casing adapter houses the mechanical seal and has an integral flush line standard for stuffing box lubrication. When the casing assembly is supplied in optional material, the casing adapter is also constructed of the same material due to the fact it is also in contact with the pumped fluid.

Stuffing Box: The stuffing box is sized for a standard, front loading mechanical seal with integral flush line. The mechanical seal is constructed of a carbon rotary face, a ceramic stationary face and buna elastomers standard.

Motor: All REI models utilize standard, stocked, C-Face motors that are available in many different voltages, speeds and enclosures. Each motor can be removed from the unit without complete disassembly of the pump. Also, pumps can be stocked complete, less driver and fully assembled ready for usage when the need arises. This flexibility allows the user more many additional options that JM motors do not offer. All REI models are driven by the motor keyway requiring no special machining or drilling operations.

INDUSTRIAL
 Process, Petrochemical, Leachate Recovery
COMMERCIAL
 HVAC, Booster, Condensate Return, Supply Water, Reverse Osmosis
MUNICIPAL
 Quench Water, Filtration, Transfer, Filter Backwash, Supply Water
PRODUCT BULLETIN
MODEL REI END SUCTION

FL - FLUID END KIT
CA - CASING ADAPTER KIT
BR - BRACKET & SHAFT KIT

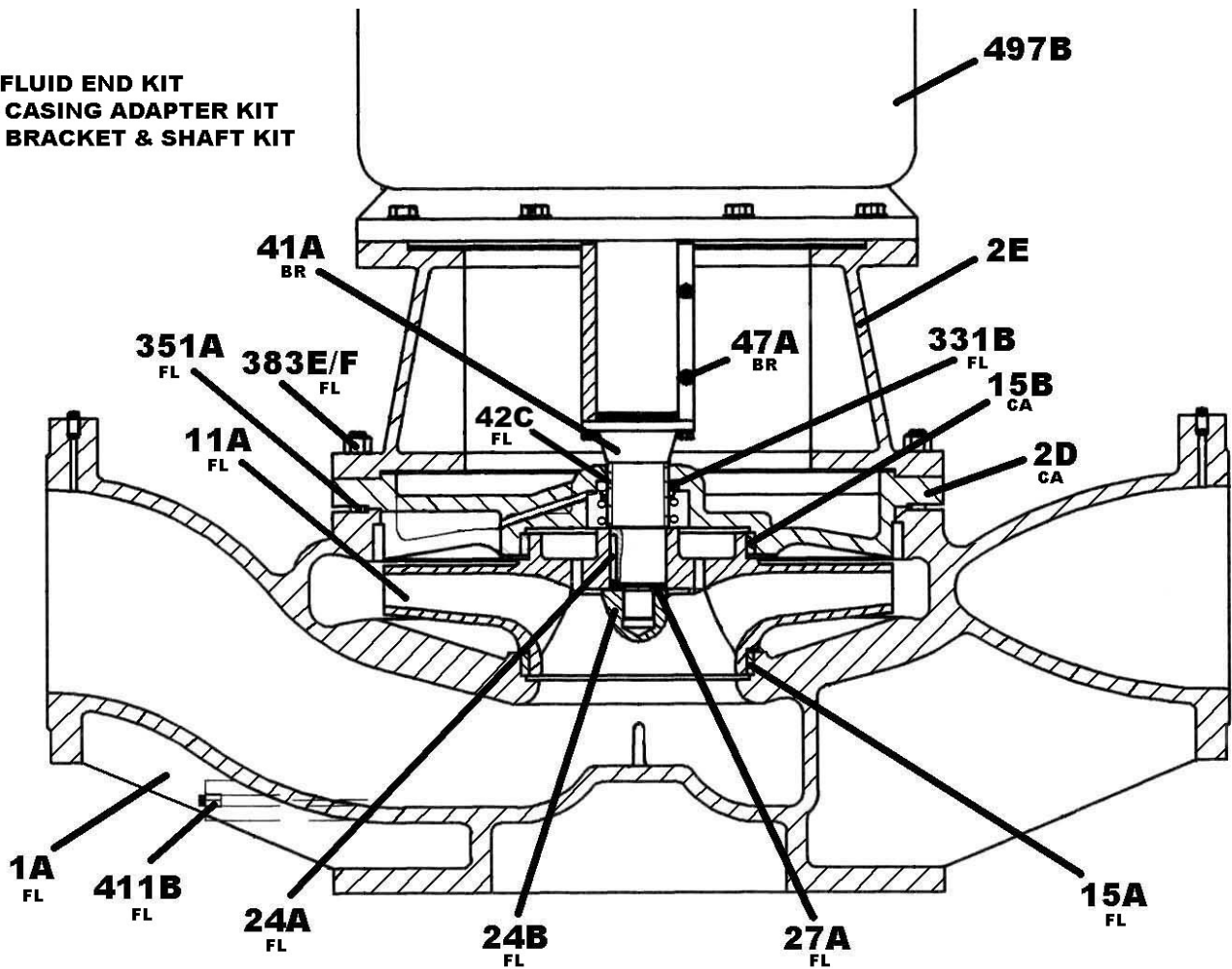

REI Sectional Drawing

Item Number	Item Description	Num. Req.
1A	Casing	1
2D	Casing Adapter	1
2E	Motor Bracket	1
11A	Impeller	1
15A	Case Wear Ring, Front	1
15B	Case Wear Ring, Rear	Varies
24A	Impeller Key	1
24B	Impeller Nut	1
27A	Impeller Washer	1

Recommended spare parts are in **BOLD**.

Item Number	Item Description	Num. Req.
41A	Shaft	1
42C	Shaft Sleeve	1
47A	Shaft Set Screw	Varies
331B	Mechanical Seal	1
351A	Casing Gasket	1
383E/F	Casing Stud & Nut	Varies
411B	Plug, Drain	1
497B	C-Face Motor	1